

TWIN PORTS AERIAL

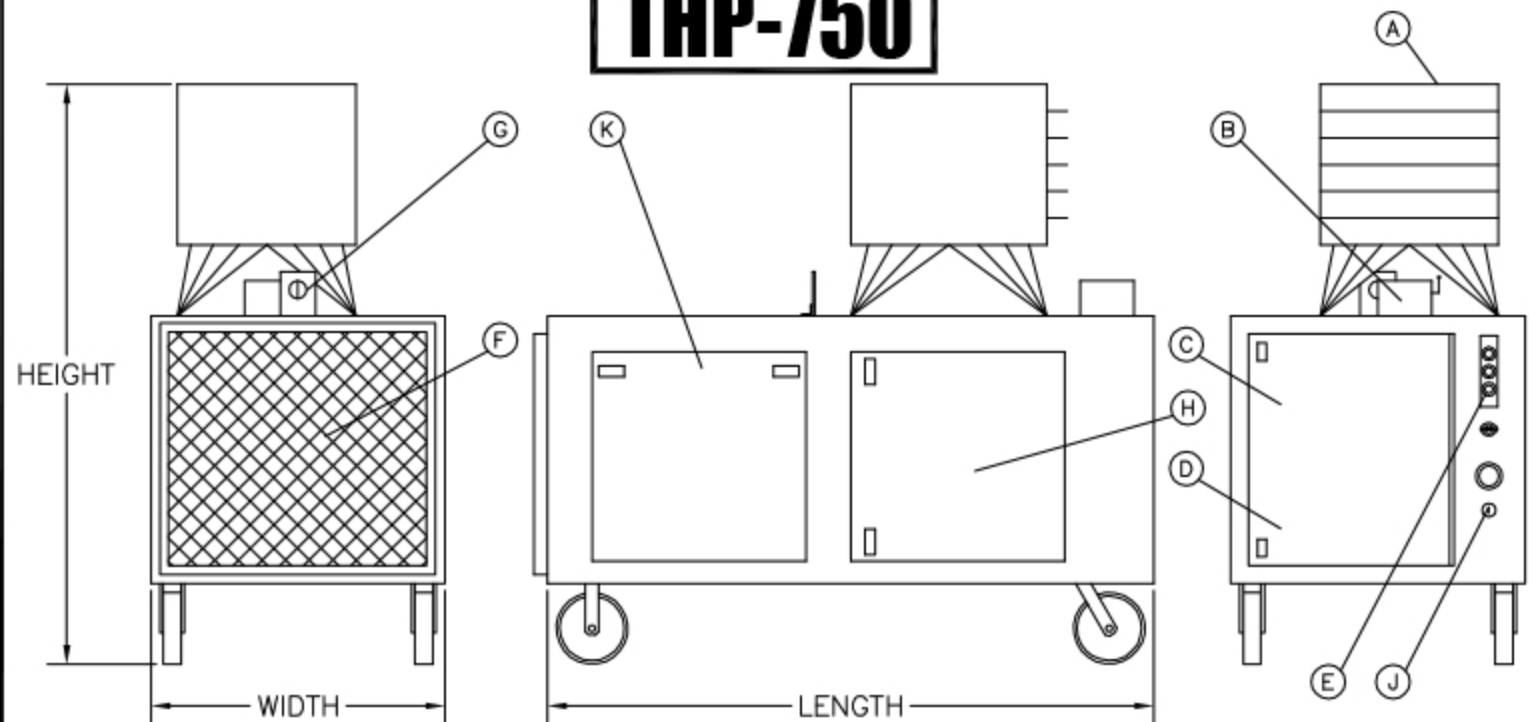

DULUTH, MN • (218) 728-4184

THP-750



UNIT SPECIFICATIONS:

POWER SUPPLY: 230V/1PH/60HZ/15A

230V/3PH/60HZ/6A

460V/3PH/60HZ/3A

AIR DELIVERY: 4,000 CFM

BTU INPUT: 43,200 - 750,000

FUEL SUPPLY:

PROPANE: 2 - 10 PSI

NATURAL GAS: 1/2 - 4 PSI

CONNECTION: 1" NPT

DIMENSIONS:

LENGTH: 68"

WIDTH: 32"

HEIGHT: 65"

WEIGHT: 757 lb

NOTE:

CONTACT TEMP-AIR FOR OTHER GAS PRESSURES.

- (A) DISCHARGE HOOD
- (B) SAFETY DISCONNECT
- (C) SERVICE ACCESS ELECTRICAL/MANIFOLD
- (D) SERVICE ACCESS MOTOR
- (E) CONTROL PANEL
- (F) INTAKE SCREEN
- (G) LIFTING EYE
- (H) SERVICE ACCESS BEARING
- (J) GAS INLET
- (K) SERVICE ACCESS BURNER

DRAWN: MACK

UPDATED: JH

DATE: 11/14/14

DATE: 09/19/16