

TWIN PORTS AERIAL

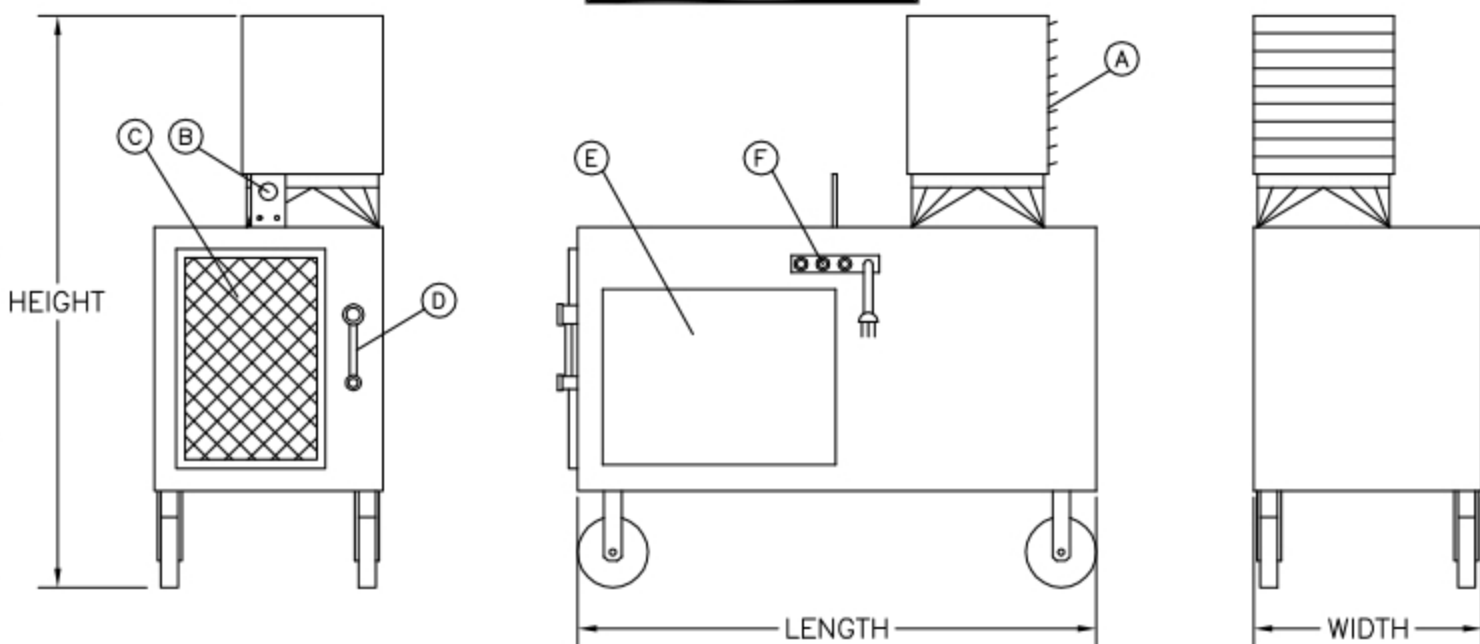

DULUTH, MN • (218) 728-4184

THP-500



UNIT SPECIFICATIONS:

POWER SUPPLY: 115V/1PH/60HZ/20A

AIR DELIVERY: 2,800 CFM

BTU INPUT: 40,300 - 500,000

FUEL SUPPLY:

PROPANE: 2 - 10 PSI

CONNECTION: 1/2" NPT

NATURAL GAS: 4 PSI

CONNECTION: 1" NPT

DIMENSIONS:

LENGTH: 59"

WIDTH: 26"

HEIGHT: 65"

WEIGHT: 560 lb

- (A) DISCHARGE HOOD
- (B) LIFTING EYE
- (C) INTAKE SCREEN
- (D) GAS INLET
- (E) SERVICE ACCESS ELECTRICAL/MANIFOLD
- (F) CONTROL PANEL

NOTE:

CONTACT TEMP-AIR FOR OTHER GAS PRESSURES.

DRAWN: ACJ	UPDATED: JH
DATE: 11/06/01	DATE: 09/21/16