

TWIN PORTS AERIAL

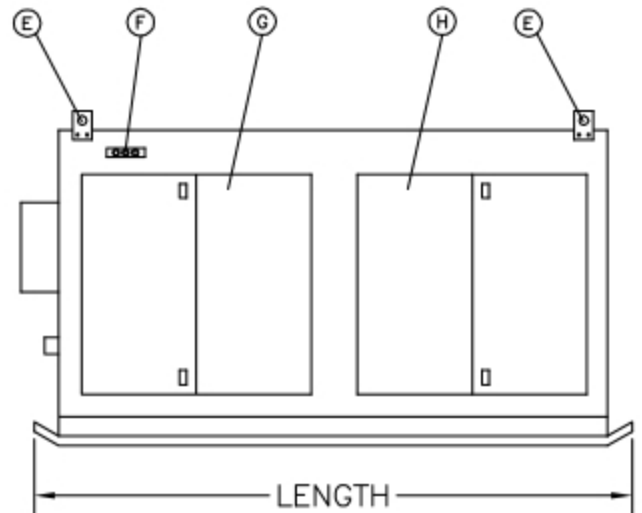

DULUTH, MN • (218) 728-4184

THP-4500

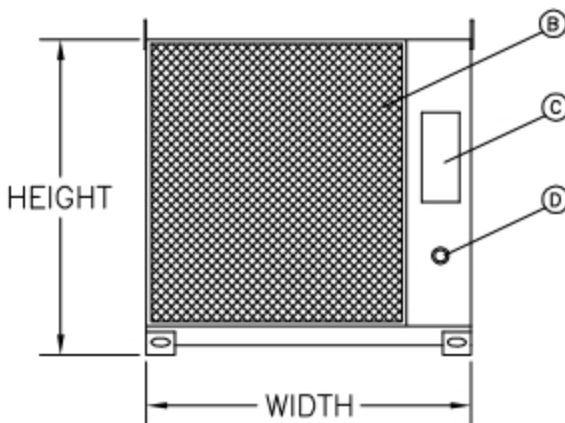
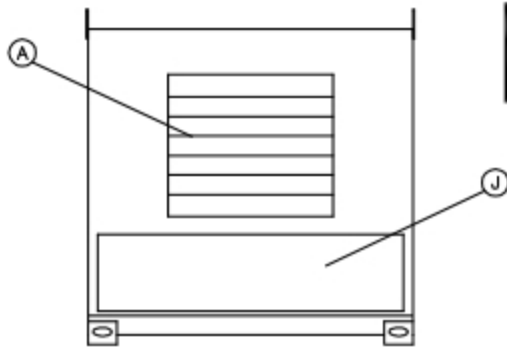

UNIT SPECIFICATIONS:

POWER SUPPLY: 230V/3PH/60HZ/60A

460V/3PH/60HZ/30A

AIR DELIVERY: 24,500 CFM

BTU INPUT: 202,500 - 4,500,00

FUEL SUPPLY:

PROPANE: 2 - 10 PSI

NATURAL GAS: 1/2 - 4 PSI

CONNECTION: 2" NPT

DIMENSIONS:

LENGTH: 125"

WIDTH: 68"

HEIGHT: 66"

WEIGHT: 2,700 lb

NOTE:

CONTACT TEMP-AIR FOR OTHER GAS PRESSURES.

UNIT COMPONENTS:

- (A) DISCHARGE DIFFUSER
- (B) INTAKE SCREEN
- (C) SAFETY DISCONNECT
- (D) GAS INLET
- (E) LIFTING EYES
- (F) CONTROL PANEL
- (G) SERVICE ACCESS ELECTRICAL & MANIFOLD
- (H) SERVICE ACCESS BLOWER/BEARINGS
- (J) SERVICE ACCESS MOTOR

DRAWN: ACJ	UPDATED: JH
DATE: 11/13/01	DATE: 9/16/16