

TWIN PORTS AERIAL

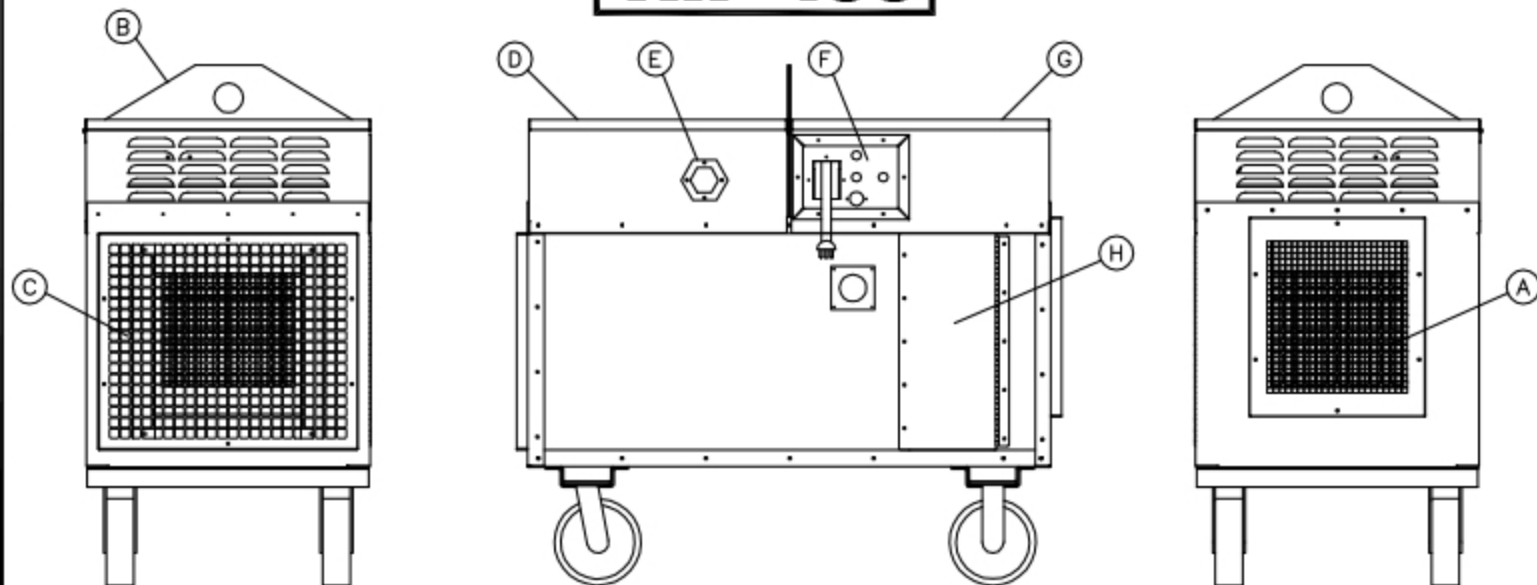

DULUTH, MN • (218) 728-4184

THP-400



UNIT SPECIFICATIONS:

POWER SUPPLY:	115V/1PH/60HZ/20A
AIR DELIVERY:	2,400 CFM
BTU INPUT:	80,000 - 400,000

FUEL SUPPLY:

PROPANE:	2 - 10 PSI
CONNECTION:	1/2" NPT
NATURAL GAS:	1/4 - 2 PSI
CONNECTION:	1" NPT

DIMENSIONS:

LENGTH:	50"
WIDTH:	26"
HEIGHT:	48"
WEIGHT:	450 lb

NOTE:

CONTACT TEMP-AIR FOR OTHER GAS PRESSURES.

- (A) DISCHARGE SCREEN
- (B) LIFTING EYE
- (C) INTAKE SCREEN
- (D) SERVICE ACCESS MANIFOLD
- (E) GAS INLET
- (F) CONTROL PANEL
- (G) SERVICE ACCESS ELECTRICAL/MOTOR
- (H) SERVICE ACCESS BEARINGS

DRAWN: ACJ	UPDATED: JH
DATE: 10/31/01	DATE: 09/26/16