

# TWIN PORTS AERIAL

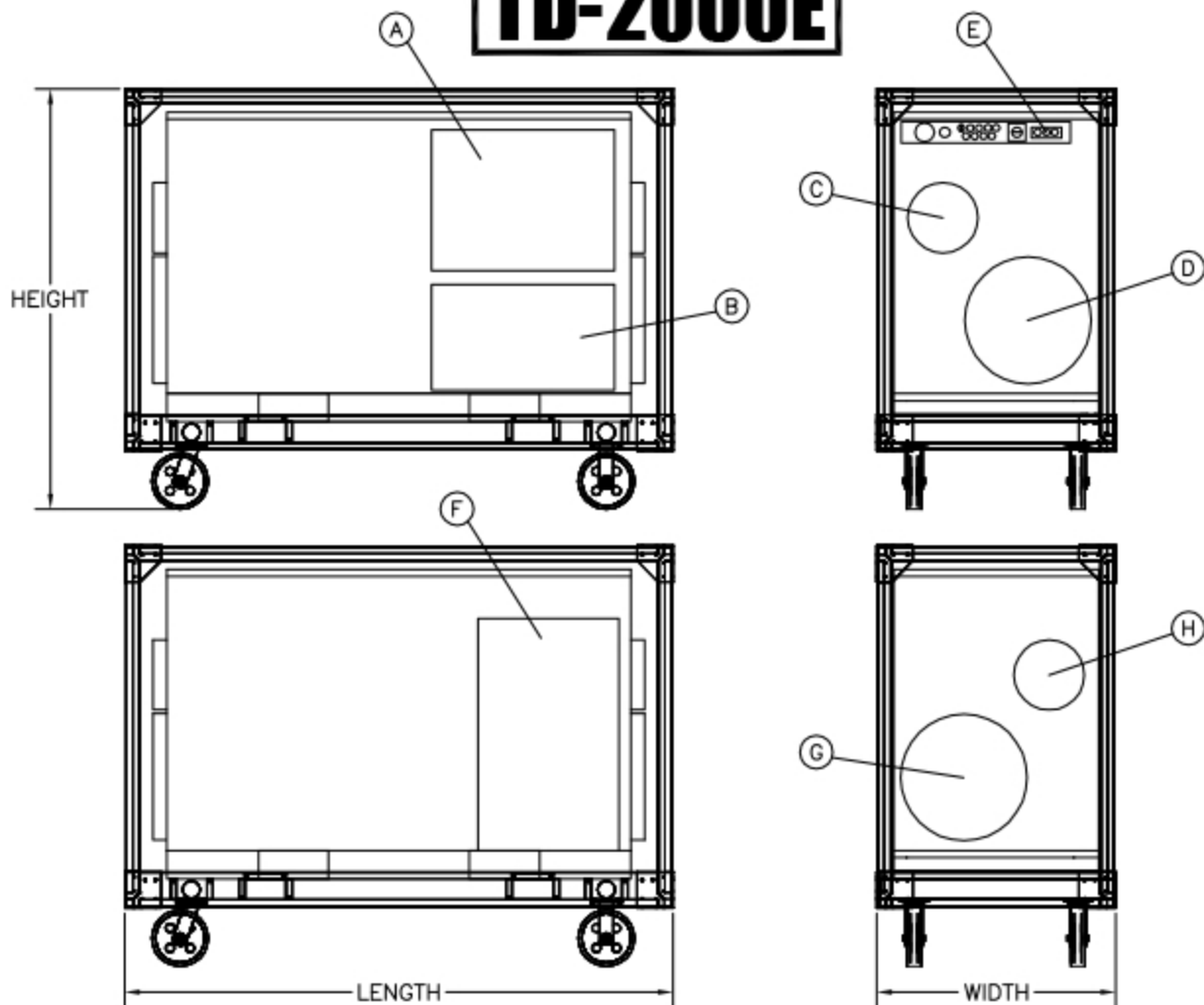

DULUTH, MN • (218) 728-4184

## TD-2000E



### UNIT SPECIFICATIONS:

POWER SUPPLY:	460V/3PH/60HZ/60MCA
AIR DELIVERY:	2000 CFM
MOISTURE REMOVAL:	143 GALLONS/DAY (80°/60% R.H.)
ESP:	2.0"

### DIMENSIONS:

LENGTH:	78"
WIDTH:	34"
HEIGHT:	60"
WEIGHT:	895 lb

- (A) FILTER ACCESS
- (B) BURNER CONTROLS
- (C) REACTIVATION AIR INTAKE (12" dia)
- (D) DRY AIR DISCHARGE (20" dia)
- (E) ELECTRICAL CONNECTION
- (F) FILTER ACCESS
- (G) WET AIR INTAKE (20" dia)
- (H) REACTIVATION AIR DISCHARGE (12" dia)

DRAWN: JT	UPDATED: JH
DATE: 02/07/02	DATE: 02/23/17