

# TWIN PORTS AERIAL

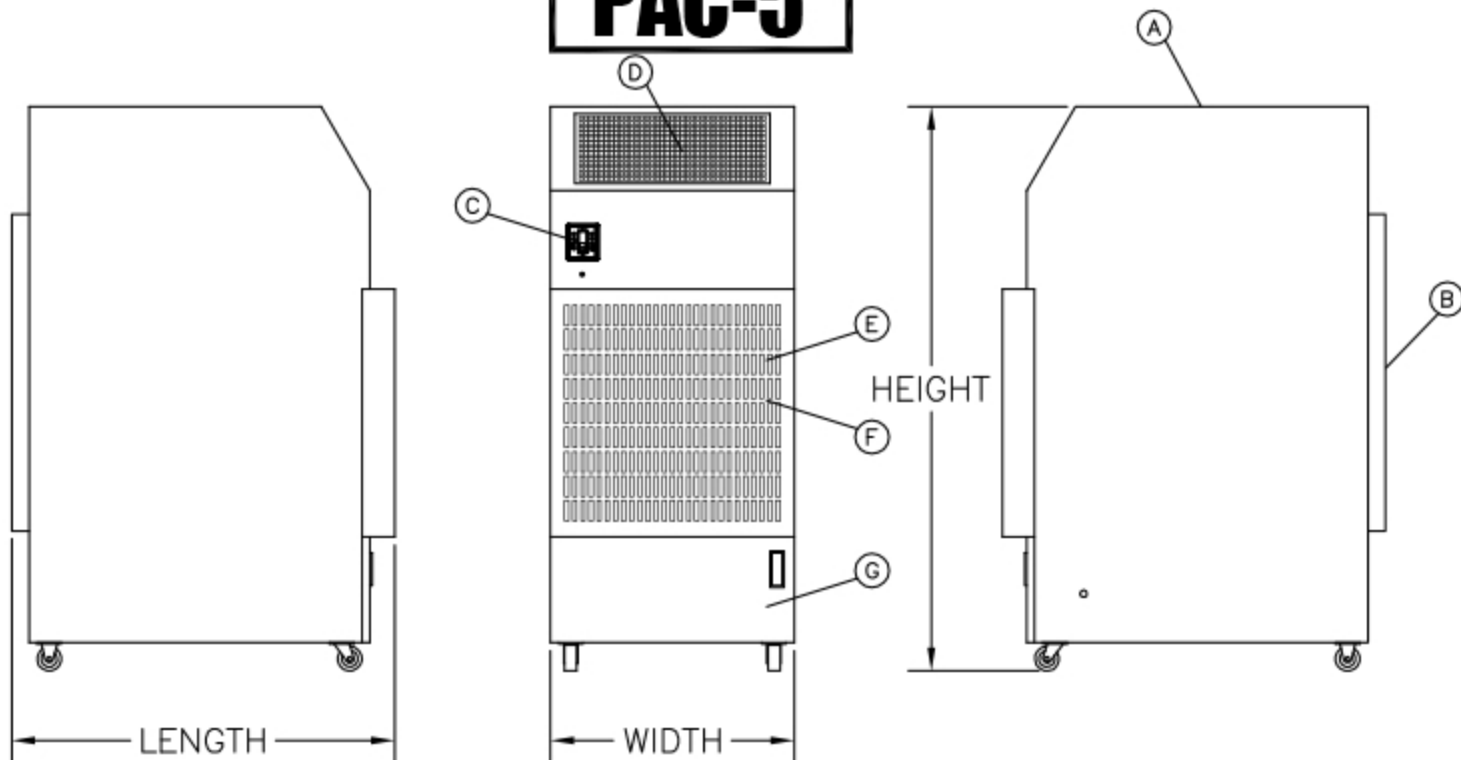

DULUTH, MN • (218) 728-4184

## PAC-5



### UNIT SPECIFICATIONS:

POWER SUPPLY: 208-230V/1PH/60HZ/60A  
AIR DELIVERY: 2,300 CFM  
CONDENSATE TANK: 5 GALLON

### DIMENSIONS:

LENGTH: 47"  
WIDTH: 30"  
HEIGHT: 70"  
WEIGHT: 640 lb

- (A) CONDENSER EXHAUST
- (B) CONDENSER INLET
- (C) THERMOSTAT
- (D) SUPPLY AIR
- (E) RETURN AIR
- (F) SERVICE ACCESS, FILTER
- (G) SERVICE ACCESS, CONDENSATE TANK

DRAWN: ACJ

UPDATED: JH

DATE: 02/06/02

DATE: 02/17/17