

TWIN PORTS AERIAL

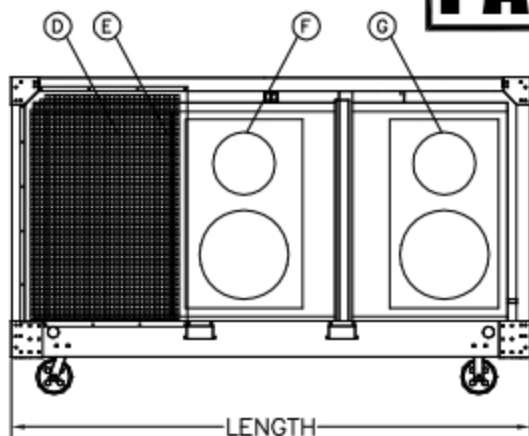

DULUTH, MN • (218) 728-4184

PAC-15T2HD



- (A) SERVICE ACCESS, BLOWER
- (B) SERVICE ACCESS, ELECTRICAL
- (C) SAFETY DISCONNECT
- (D) CONDENSER INLET
- (E) CONDENSER EXHAUST
- (F) SUPPLY AIR 14" dia & 20" dia
- (G) RETURN AIR 14" dia & 20" dia
- (H) SERVICE ACCESS, FILTER
- (J) CONDENSATE DRAIN CONNECTION

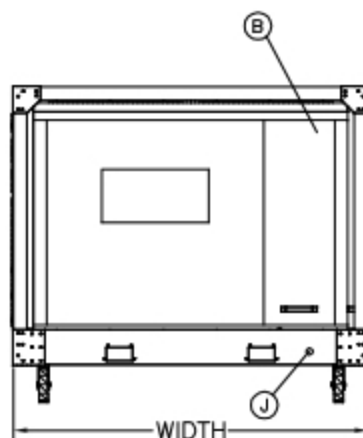
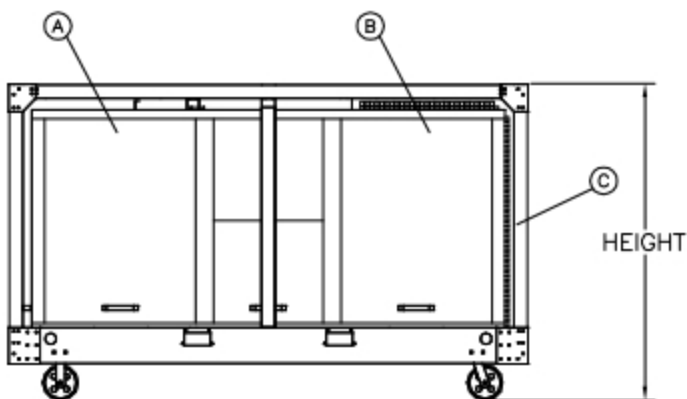

UNIT SPECIFICATIONS:

POWER SUPPLY: 230V/3PH/60HZ
 AIR DELIVERY: 6000 CFM
 HEATER ELEMENT: 54 KW
 DRAIN CONNECTION: 1" NPT
 SOUND POWER LEVEL: 90dba

DIMENSIONS:

LENGTH: 117"
 WIDTH: 80"
 HEIGHT: 71"
 WEIGHT: 1950 lb

MODE:

COOL ONLY: 85 MCA
 HEAT OR COOL: 185 MCA
 DEHUMIDIFY: 255 MCA

| | |
|----------------|----------------|
| DRAWN: ACJ | UPDATED: JH |
| DATE: 01/31/02 | DATE: 02/15/17 |