

# TWIN PORTS AERIAL

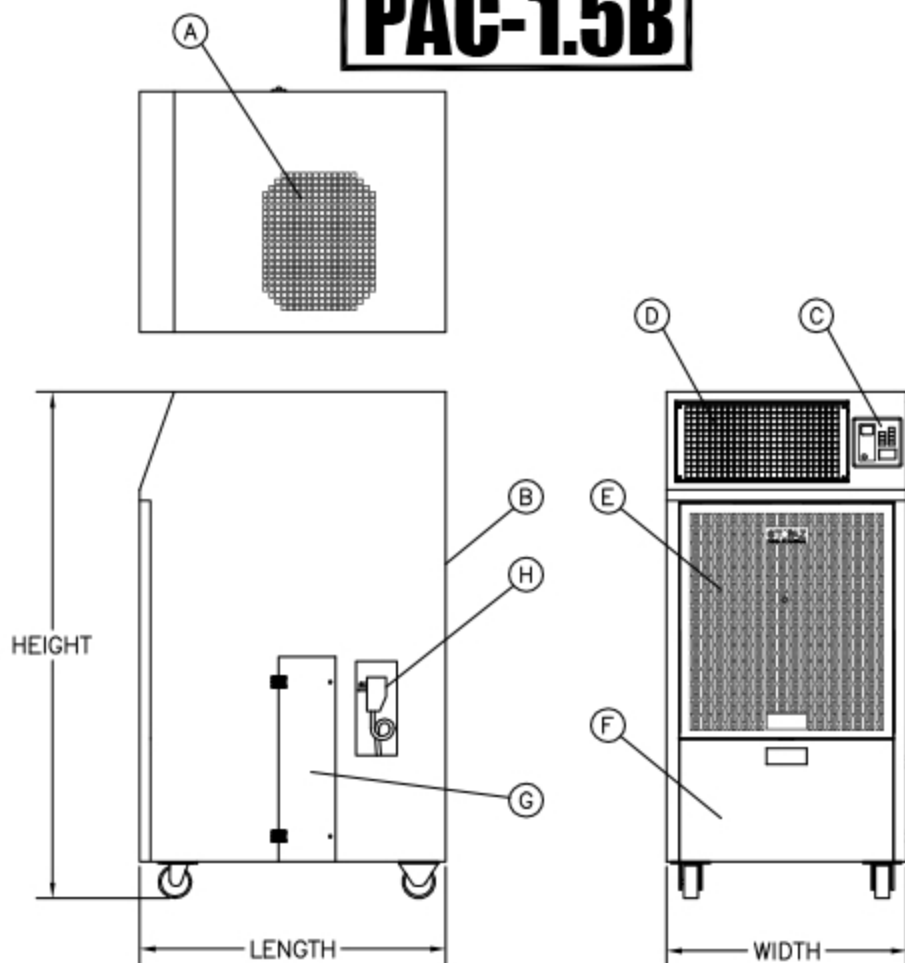

DULUTH, MN • (218) 728-4184

## PAC-1.5B



### UNIT SPECIFICATIONS:

POWER SUPPLY: 115V/1PH/60HZ/15A  
AIR DELIVERY: 500 CFM  
COOLING CAPACITY: 17,300 BTU  
CONDENSATE TANK: 5 GALLON

### DIMENSIONS:

LENGTH: 22"  
WIDTH: 28"  
HEIGHT: 46"  
WEIGHT: 250 lb

- (A) CONDENSATE EXHAUST
- (B) CONDENSER INLET
- (C) THERMOSTAT
- (D) SUPPLY AIR
- (E) RETURN AIR
- (F) SERVICE ACCESS, CONDENSATE TANK
- (G) ELECTRICAL PANEL ACCESS
- (H) POWER SUPPLY

DRAWN: MACK	UPDATED: JH
DATE: 09/13/12	DATE: 02/15/17