

TWIN PORTS AERIAL

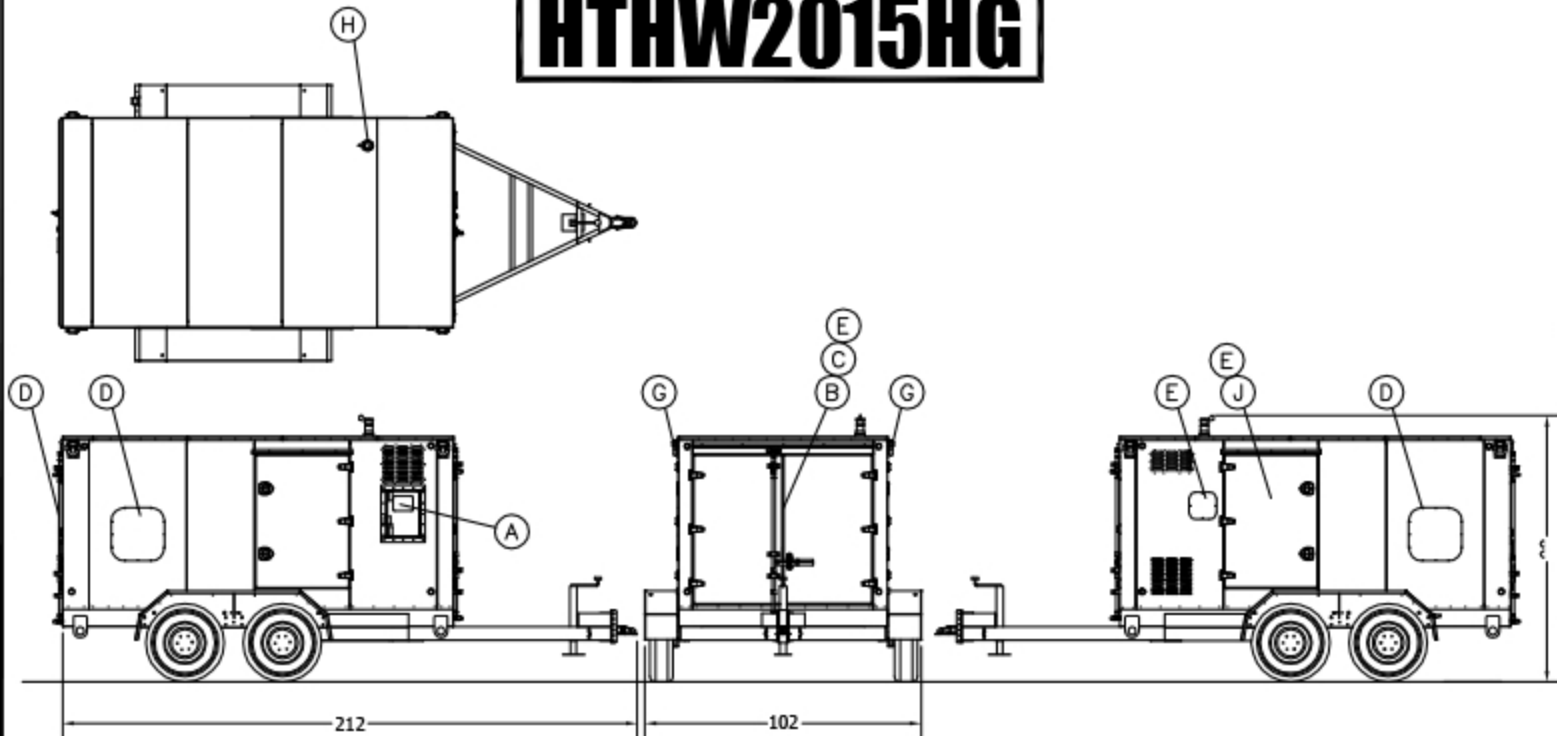

DULUTH, MN • (218) 728-4184

HTHW2015HG



UNIT SPECIFICATIONS:

BTU/HR INPUT: 360,000

FUEL SUPPLY:

FUEL TYPE: DIESEL FUEL, 3.2GPH

FUEL CAPACITY: 230 GALLONS

DIMENSIONS:

LENGTH: 212"

WIDTH: 102"

HEIGHT: 98"

WEIGHT: 7350 lb

WEIGHT (FULL FUEL): 8960 lb

- (A) CONTROL PANEL
- (B) ENGINE ACCESS
- (C) MAIN PUMP
- (D) ACCESS 1500' HOSE REEL (2)
- (E) PROPYLENE GLYCOL TANK, 50/50 MIX
- (G) LIFTING POINTS (4)
- (H) ENGINE EXHAUST
- (J) FILL PUMP ACCESS

DRAWN: MF

UPDATED: JH

DATE: 01/05/16

DATE: 05/15/17