

TWIN PORTS AERIAL

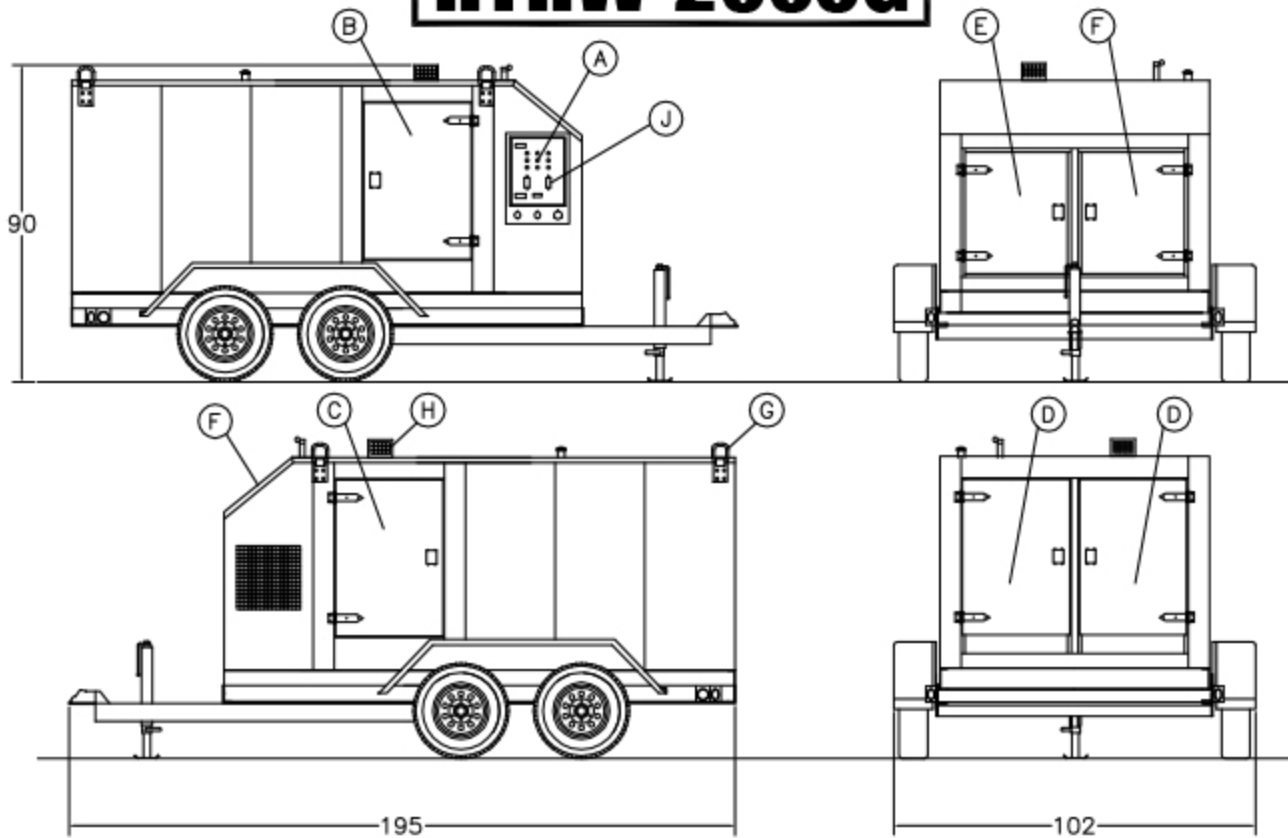

DULUTH, MN • (218) 728-4184

HTHW-2000G



UNIT SPECIFICATIONS:

POWER SUPPLY: (2) 120V/1PH/60HZ/15A
 (1) 230V/1PH/60HZ/20A/4 WIRE
 (1) 8KW DIESEL GENERATOR

BTU-HR INPUT: 280,000

FUEL SUPPLY:

FUEL OIL TYPE: #1, #2 2.65 GPH

DIMENSIONS:

LENGTH: 195"
 WIDTH: 102"
 HEIGHT: 90"
 WEIGHT: 7,860 lb (NO FUEL)
 WEIGHT: 8,910 lb (FULL FUEL)

- (A) CONTROL PANEL/POWER INLET
- (B) BOILER ACCESS
- (C) PUMP ACCESS/FUEL FILL 150 GAL DIESEL (EMP OIL FOR GENERATOR) 4 GAL. 10-30 ROTELLA
- (D) ACCESS, HOSE REELS
- (E) PROPYLENE GLYCOL TANK 50/50 MIX
- (F) GENERATOR ACCESS
- (G) LIFTING POINTS
- (H) BOILER EXHAUST
- (J) (2) 15 AMP, 120 VOLT OUTLETS (WHEN GENERATOR IS RUNNING)

DRAWN: JT	UPDATED: JH
DATE: 03/05/07	DATE: 05/15/17