

# TWIN PORTS AERIAL

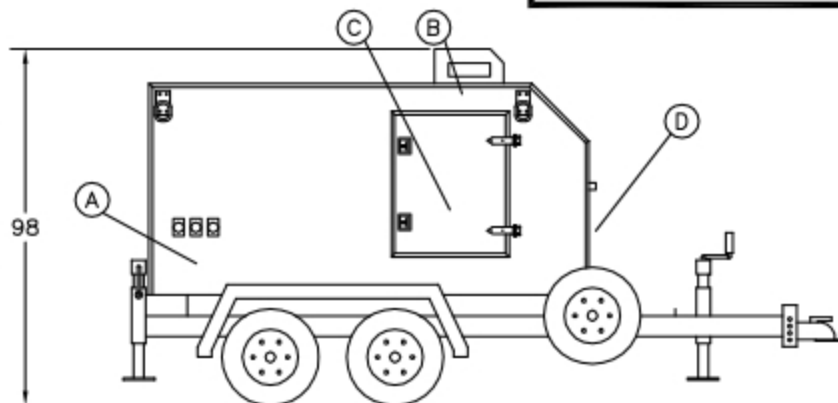

DULUTH, MN • (218) 728-4184

## HTHW-2000



- (A) POWER INLETS
- (B) BOILER EXHAUST
- (C) SERVICE ACCESS: BOILER, TANK, PUMPS
- (D) GAS INLET
- (E) JACKS
- (F) FUEL FILL (#1 FUEL OIL ONLY)
- (G) LIFTING EYES
- (H) SERVICE ACCESS, HOSE REELS
- (J) INTERNAL FUEL TANK: 150 GALLONS

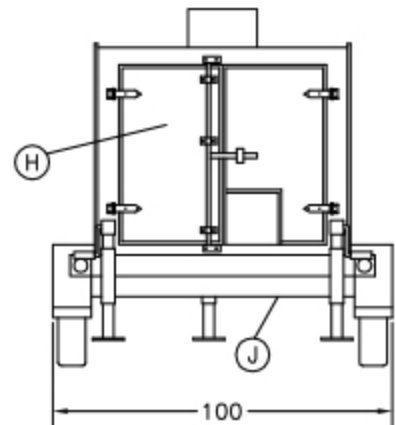
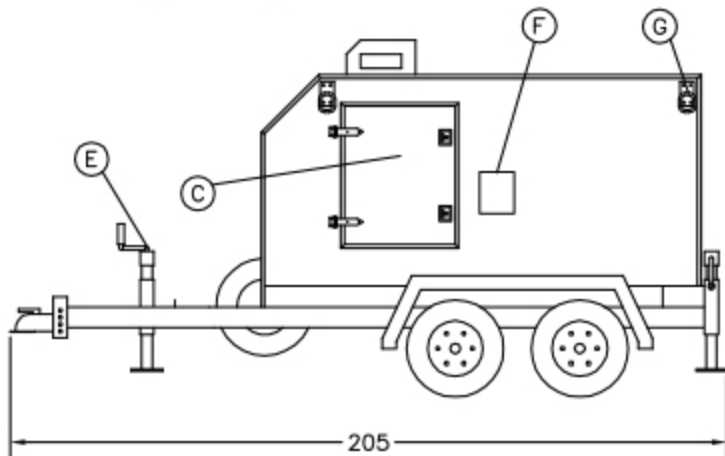

### UNIT SPECIFICATIONS:

POWER SUPPLY: (2) 120V/1PH/60HZ/15A  
 (1) 230V/1PH/60HZ/20A/4 WIRE

BTU/HOUR INPUT: 280,000

### FUEL SUPPLY:

PROPANE: 10 PSI 3.0 GPH

NATURAL GAS: 1/4 - 10 PSI 280 CFH

FUEL OIL TYPE: #1 2.0 GPH

GAS CONNECTION: 1" NPT

### DIMENSIONS:

LENGTH: 205"

WIDTH: 100"

HEIGHT: 98"

WEIGHT: 7,400 lb

WEIGHT FULL FUEL: 8,400 lb

DRAWN: ACJ	UPDATED: JH
DATE: 01/15/01	DATE: 05/15/17